

I-T Characteristics / 時間-電流特性

Ampere Rating 額定電流	% of Ampere Rating 額定電流%	Opening Time 熔斷時間
100mA~6.3A	150%	1 Hr Min. / 最短1小時
100mA~6.3A	210%	2min Max. / 最長2分鐘
100mA	275%	200ms Min. 10s Max. / 最短200毫秒, 最長10秒
125mA~6.3A		600ms Min. 10s Max. / 最短600毫秒, 最長10秒
100mA	400%	40ms Min. 3s Max. / 最短40毫秒, 最長3秒
125mA~6.3A		150ms Min. 3s Max. / 最短150毫秒, 最長3秒
100mA	1000%	10ms Min. 300ms Max. / 最短10毫秒, 最長300毫秒
125mA~6.3A		20ms Min. 300ms Max. / 最短20毫秒, 最長300毫秒

In accordance with IEC60127-2 standard, sheet3 / 遵循IEC60127-2, 規格單3



Product Features / 產品特性

Materials 材質	Body / 本體: glass tube / 玻璃管 Lead / 引線: tinned copper wire / 鍍錫銅線 Cap / 銅帽: brass with nickel plated / 銅鍍鎳 Element / 熔絲: alloy / 合金線
Operating Temperature 操作溫度	-55°C to +125°C (consider de-rating / 需考慮溫度折減)
Solderability 可焊性	260°C, ≤ 3s. (wave / 波峰焊) 350±10°C, ≤ 3s. (soldering iron / 烙鐵焊)
Resistance to Soldering Heat 耐焊接熱	260°C, 10s. (wave / 波峰焊) 350°C, 5s. (soldering iron / 烙鐵焊)
Recommended Soldering Parameters 建議焊錫參數	Wave soldering parameter / 波峰焊 Soldering pot temperature / 錫爐溫度: 260°C Max Solder dwell time / 焊接時間: 2~5s Hand welding parameter / 手工焊 Soldering iron temperature / 烙鐵溫度: 350±5°C Solder dwell time / 焊接時間: 5s Max.
Storage Conditions 儲存條件	Can be stored for 3 years under tight seal condition at temperature of +10°C~60°C, relative humidity ≤ 75%. 在溫度+10°C~60°C, 相對濕度 ≤ 75% 的密閉條件下可存放 3 年。 At most can be kept 30 days at temperature +10°C~60°C, relative humidity ≤ 95% under covered conditions. 在溫度+10°C~60°C, 相對濕度為 95% 的非露天下最多可存放 30 天。

Dimensions / 尺寸圖 (Unit / 單位:mm)

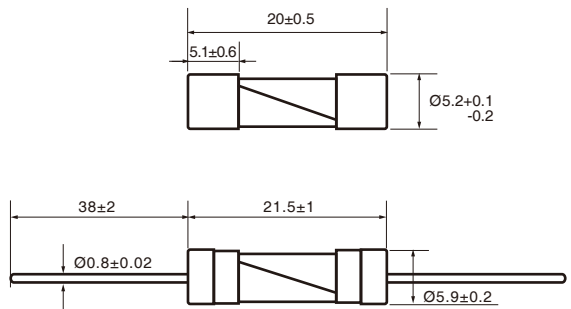

Electrical Characteristics / 電氣特性

Rated Current 額定電流	Rated Voltage 額定電壓	Breaking Capacity 分斷能力	Safety Approvals 安全認證					
			UL	VDE	CSA	CCC	CCC	JET
100mA	Obsolete & Replaced by TMD 100mA		●	●	●	●	●	
125mA	Obsolete & Replaced by TMD 125mA		●	●	●	●	●	
200mA	Obsolete & Replaced by TMD 200mA		●	●	●	●	●	
250mA	Obsolete & Replaced by TMD 250mA		●	●	●	●	●	
315mA	Obsolete & Replaced by TMD 315mA		●	●	●	●	●	
400mA	Obsolete & Replaced by TMD 400mA		●	●	●	●	●	
500mA	Obsolete & Replaced by TMD 500mA		●	●	●	●	●	
630mA	250V	630mA~3.15A 35A@250V AC	●	●	●	●	●	
800mA	250V		●	●	●	●	●	
1.00A	250V		●	●	●	●	●	●
1.25A	250V		●	●	●	●	●	●
1.60A	250V		●	●	●	●	●	●
2.00A	250V		●	●	●	●	●	●
2.50A	250V		●	●	●	●	●	●
3.15A	250V	●	●	●	●	●	●	
4.00A	250V	4A~6.3A 10IN@250V AC	●	●	●	●	●	●
5.00A	250V		●	●	●	●	●	●
6.30A	250V		●	●	●	●	●	●
			●	●	●	●	●	●